

DF200AP NEW

Lightweight design, heavy weight power

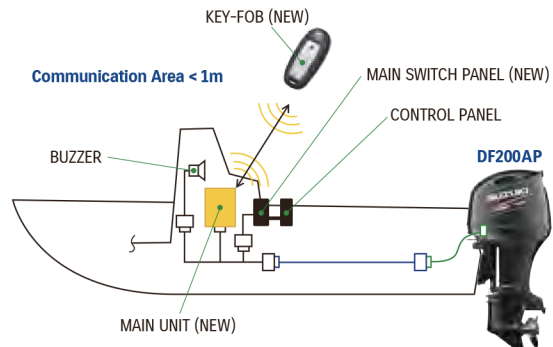

Advanced features only found on the DF200AP

- **Suzuki Precision Control (Electronic Throttle and Shift System) delivers smooth and positive gear operation.**
- **Suzuki Selective Rotation enables the outboard to operate in either regular or counter rotation modes giving greater versatility.**
- **Suzuki Keyless Start System - first in class innovation.**

MODEL	DF200AP
SHAFT LENGTH mm	L:508 X:635
STARTING SYSTEM	Electric
WEIGHT kg	L: 228 X: 233
ENGINE TYPE	DOHC 16-Valve
FUEL DELIVERY SYSTEM	Multi Point EFI
NO. OF CYLINDERS	In-Line 4
PISTON DISPLACEMENT cm ³	2,867
BORE x STROKE m/m	97 x 97
MAXIMUM OUTPUT kW	147.0 (200)/5,800rpm
FULL THROTTLE OPERATING RANGE rpm	5,500-6,100
STEERING	Remote
OIL PAN CAPACITY (litres)	8.0
IGNITION SYSTEM	Transistorised
ALTERNATOR	12V 44A
ENGINE MOUNTING	Shear Mount
TRIM METHOD	Power Trim & Tilt
GEAR RATIO	2.50:1
GEAR SHIFT	F-N-R
EXHAUST	Through prop
PROPELLOR SELECTION (Pitch)	17" - 27.5"

**SUZUKI
SELECTIVE ROTATION**

LEAN BURN 

Suzuki Precision Control